

JOINTLY ORGANISED BY



WORLD WORKPLACE ASIA 2019

3 - 5 April 2019 | Marina Bay Sands, Singapore

BUILDING THE FUTURE OF FACILITY MANAGEMENT THROUGH DIGITAL INNOVATION



JOINTLY ORGANISED BY



WORLD WORKPLACE ASIA 2019

3-5 April 2019 • Marina Bay Sands, Singapore

World Workplace Asia 2019 is proud to have the support from the following organisations.

SUPPORTED BY



TRACK PARTNER



PLATINUM SPONSOR



GOLD SPONSORS



SILVER SPONSORS



ECO-BAG SPONSOR



LANYARD SPONSOR



STUDENT AWARD CATEGORY SPONSOR



EXHIBITORS



FACILITY SITE HOSTS



CONTENT

About the Organisers	04
Welcome Message from Building and Construction Authority	05
Welcome Message from International Facility Management Association (IFMA)	06
Welcome Message from IFMA Singapore Chapter	07
Day 1 Conference Programme	08
Day 2 Conference Programme	09
Day 1 Spotlight Plenary	10
Day 1 Conference Sessions	11
Day 2 Conference Sessions	15
Day 1 Cocktail Networking Reception & Conference Venue	18
Ballroom Layout & Exhibition Floor Plan	19
Day 3 Facility Site Tour	20
Sponsor & Exhibitor Profiles	21

EVENT ORGANISING COMMITTEE

Steering Committee

- **Donald L Gilpin** – Chief Operating Officer, IFMA
- **Leong-Kok Su-Ming** – Managing Director, BCA Academy, BCA
- **Paul Juwono** – Director, School of Graduate Development & Management, BCA Academy, BCA
- **Tony Khoo** – Chief Executive Officer, EM Services Pte Ltd & President, IFMA Singapore Chapter

Programme & Planning Committee

- **Ann Loayza, CMP** – Director, Events, IFMA
- **Michael Ng Khai Loon** – Vice-President, IFMA Singapore Chapter
- **Ken Mong** – Deputy Director (Continuing Education and Training), School of Graduate Development and Management, BCA Academy, BCA
- **Grace Teo** – Head (Academic Programme), School of Graduate Development & Management, BCA Academy, BCA
- **Wong Mee York** – Assistant Head (Programme Administration), School of Graduate Development and Management, BCA Academy, BCA
- **Celes Cheng** – Higher Associate (Programme Administration), School of Graduate Development & Management, BCA Academy, BCA
- **Siti Nabilah** – Higher Associate (Programme Administration), School of Graduate Development & Management, BCA Academy, BCA
- **Siti Raodah** – Higher Associate (Programme Administration), School of Graduate Development & Management, BCA Academy, BCA

ACCESSING THE CONFERENCE PROCEEDINGS AND HANDOUTS

In keeping with our green and sustainable conference initiatives, delegates can gain access to conference materials including proceedings and PowerPoint presentations online.



Simply log on to the conference link at https://events.ifma.org/worldworkasia/2018/handout_download_general.cfm
Alternatively, you may scan on the QR code provided to access the conference materials.

ONLINE EVALUATION



We would appreciate it if you could take some time to complete the e-Evaluation to provide us with your valuable feedback by accessing the survey link at <http://tinyurl.com/y5lv6umu>

ABOUT THE ORGANISERS



BCA ACADEMY

BUILDING AND CONSTRUCTION AUTHORITY

The Building and Construction Authority (BCA) of Singapore champions the development of an excellent built environment for Singapore. BCA's mission is to shape a safe, high quality, sustainable and friendly built environment, as these are four key elements where BCA has a significant influence. In doing so, it aims to differentiate Singapore's built environment from those of other cities and contribute to a better quality of life for everyone in Singapore. Hence, its vision is to have "a future-ready built environment for Singapore". Together with its education arm, the BCA Academy of the Built Environment, BCA works closely with its industry partners to develop skills and expertise that help shape a future-ready built environment for Singapore. For more information, visit www.bca.gov.sg.

For more information, visit www.bca.gov.sg and www.bcaa.edu.sg



INTERNATIONAL FACILITY MANAGEMENT ASSOCIATION

Founded in 1980, IFMA is the world's largest and most widely recognized international association for facility management professionals, supporting more than 24,000 members in more than 100 countries. The association's members, represented in 136 chapters and 16 councils worldwide, manage more than 78 billion square feet of property and annually purchase more than US\$526 billion in products and services. Formed in 1980, IFMA certifies professionals in facility management, conducts research, provides educational programs and produces World Workplace, the world's largest facility management conference and exposition. To join and follow IFMA's social media outlets online, visit the association's LinkedIn, Facebook, YouTube and Twitter pages.

For more information, visit the [IFMA press room](#) or www.ifma.org



SINGAPORE CHAPTER OF INTERNATIONAL FACILITY MANAGEMENT ASSOCIATION

The Singapore Chapter of IFMA was first conceptualized in 2000 and became an official society in Singapore in August 2001. The objective of the local chapter is to develop Facility Management as a profession, while advancing careers of individual members. The local chapter also runs regular educational programmes, best practice seminars and site visits. These events provide opportunities for members to learn and network with the industry.

For more information, please visit <http://ifmasingapore.org>

BUILDING AND CONSTRUCTION AUTHORITY



JOHN KEUNG
Dean
BCA Academy

Welcome to the World Workplace Asia Conference 2019!

Together with International Facility Management Association (IFMA) and IFMA Singapore Chapter, we are excited to host the World Workplace Asia in Singapore for the 3rd time after having hosted the inaugural Asian conference in 2012 and a subsequent run in 2015.

Singapore's Real Estate Industry Transformation Map (REITM) was launched last year to focus on transforming the Facilities Management (FM) and property transaction services sector in driving innovation and leverage technology; as well as to strengthen professionalism and upskill the workforce. Following the launch of the ITM, BCA set up the tripartite Facility Management Implementation Committee (FMIC) comprising building owners, Facility Management (FM) firms and the trade associations and chambers (TACs) to co-develop strategies and initiatives to enhance the service delivery of FM companies as well as to uplift the FM industry as a whole. Some early key recommendations by the FMIC include enhancing design for maintainability, optimising effectiveness through smart FM solutions as well as continually developing and upgrading the FM profession. This year's World Workplace Asia Conference, aptly themed "Building the Future of Facility Management through Digital Innovation", provides an excellent platform for FM practitioners from around the world to network and exchange ideas while gaining insights from local and international experts. The agenda for the conference this year draws attention to key topics on innovation and cutting-edge technologies, visioning for the future of workplaces as well as updates on FM standards. Complementing the conference, the product and service desktop exhibition and the facility site tours further showcase the innovations and best practices for FM performance through technology and digitalisation efforts.

While technology is a key enabler, we see developing the FM workforce critical to uplifting the FM industry as well as to build FM competency and capability to support the transformation. I would like to thank our long-standing partners IFMA and IFMA Singapore Chapter in planning and organising this event. I also wish to thank the event sponsors, exhibitors, track partner, speakers and delegates for their generous support and participation.

This year marks the bicentennial year for Singapore since its founding by Sir Stamford Raffles. Singapore has since evolved throughout history to what it is today. While we reflect on the challenges we faced in building this modern city, we can also look forward and chart our future together. In this current era of technology, let's continue to work hand-in-hand to stay ahead of the curve to create value for society and the larger community, for many more bicentennials to come.

I wish you a productive conference and to our friends from abroad, I wish you a pleasant stay in Singapore.

INTERNATIONAL FACILITY MANAGEMENT ASSOCIATION (IFMA)



GRAHAM TIER
CFM, MRICS
Chair, Global Board
of Directors

On behalf of the global and Asia-Pacific regional advisory boards of the International Facility Management Association; our partners, the Building and Construction Authority and the Singapore Chapter of IFMA; and our sponsors and exhibitors, I'm honored to welcome you to IFMA's World Workplace Asia 2019 Conference and Expo in Singapore.

As technical complexity and resource challenges grow throughout Asia and around the world, the role of facility management in enabling buildings and people to perform at their peak is increasingly important. This is especially vital here in one of the world's most densely populated countries.

Fortunately, Singapore is taking a leadership role in this area, with BCA advocating for 80 per cent of buildings to be green by 2030. This trend is evidenced by projects from the CapitaGreen wind scoop in the CBD to the net-zero energy School of Design and Environment at the National University of Singapore. In this context, the theme of this year's conference, Building the Future of Facility Management Through Digital Innovation, is particularly relevant.

To enable this vision for a sustainable future, IFMA has prioritized global unification within the FM sector. Recently, a collaborative multi-national effort to standardize FM resulted in the publication of three new ISO standards:

- FM vocabulary;
- Guidance on strategic sourcing and the development of agreements; and
- Scope, key concepts and benefits.

This means that the definition of the profession has been set — with input from IFMA members — at the highest level by the International Organization for Standardization. ISO now officially defines FM as an “organizational function which integrates people, place and process within the built environment with the purpose of improving the quality of life of people and the productivity of the core business.” To learn more, join the session by Stephen Ballesty on the latest ISO 41000 FM standards on Day 2 of the conference.

Beyond ISO standards, this week's program includes valuable presentations on leveraging new and upcoming technologies to shape the smart city revolution. If you're not already a member of IFMA, I encourage you to join for year-round access to resources on this topic. And, contribute to advancing our profession by joining the global celebration of World FM Day on 15 May (<http://bit.ly/worldfmday2019>).



IFMA SINGAPORE CHAPTER



TONY KHOO
President,
IFMA Singapore Chapter

On behalf of International Facility Management Association (IFMA) Singapore Chapter, I welcome all to World Workplace Asia 2019. To our overseas friends and participants, a warm welcome to the dynamic Singapore and timely visit to soak into the atmosphere of Singapore's bicentennial celebration.

World Workplace Asia (WWA) is the Asian version of the world renowned must-visit World Workplace facility management conference-cum-exhibition which is held in US every year. WWA is also held every year in Asia but rotated among the three Asian Chapters, namely, Singapore, Hong Kong and Shanghai. Singapore hosted WWA back in 2012 and 2015 and this year we are happy to co-host it again with our partners IFMA (US) and Building and Construction Authority of Singapore (BCA).

WWA is not just the ideal place for FM professionals and practitioners from the diversified regions within Asia to come together to compare notes, exchange ideas, catch up with old friend while making new ones. But, it is also the place where our fellow friends and colleagues from the West are attracted to come and see for themselves the immense opportunities that are sprouting out in Asia. We are hungry to learn from them and I am sure they are as keen to want to understand some of the interesting challenges facing this part of the world as well.

The theme for WWA 2019, "Building The Future of Facility Management Through Digital Innovation" aptly reflects how digital technology is disrupting our industry. Building owners, facility managers, users and commercial tenants are getting ever more concerned about how landscape will change with digitalization. It is no longer adequate for FM people to react and respond quickly. We must now innovate ourselves to remain relevant. We must embrace FMtech or face elimination.

Everything is now instant and that calls for a completely different mind-set as well as skill sets. Singapore FM industry itself is also undergoing a major transformation. That is why we are all here to listen and learn from our distinguished speakers and panellists at WWA 2019.

Last but not least, I like to extend my deepest appreciation to all the sponsors and partners who have supported us and helped make this event a success.

I wish all an enjoyable and fruitful gathering.



TIME	EVENT	
08:30	REGISTRATION OPENS	
09:05	WELCOME REMARKS - Mr Tony Khoo , CEO, EM Services & President, IFMA Singapore Chapter	
09:10	OPENING REMARKS - Mr Graham Tier , Chair of IFMA's Global Board of Directors	
09:15	PRESENTATION OF TOKEN OF APPRECIATION TO SPONSORS AND PARTNERS	
09:25	PRESENTATION OF STUDENT AWARD WINNER	
09:40	SPOTLIGHT PLENARY FM TRENDS AND BEST PRACTICES IN TIMES OF DIGITAL DISRUPTION: A GLOBAL PERSPECTIVE Prominent local and international panellists will address emerging trends and best practices for facility management in the midst of digital disruption. A sharing session of the perspectives on Singapore's FM sector will be included. PANEL SPEAKERS Mr Graham Tier , Chair of IFMA's Global Board of Directors Mr Ang Kian Seng , Group Director/Environmental Sustainability Group, BCA Mr Kenneth Foo , Executive Director/Property Management, Hong Kong Land Mr Jeffrey Budimulia , Director, CRE Advisors Pte Ltd & Past Director, Board of Directors of IFMA, IFMA Fellow Mr Stephen Ballesty , Director, In-Touch Advisory, IFMA Fellow (Panel Moderator) Mr Tony Khoo , CEO, EM Services & President, IFMA Singapore Chapter	
11:20	OPENING OF EXHIBITION & MORNING REFRESHMENTS	
12:00	Session 2.01	
	PANEL DISCUSSION CRE/FM MARKET TRENDS IN APAC – SERVICE PROVIDERS ON THE SPOT Mr Michael Runicles , APAC COO GWS, CBRE Mr Mark Hunter , International Director, JLL Mr Abel Ariza , Regional Director APAC, Sodexo Mr Andrew Scott Dale , Director, Global Occupier Services, Cushman & Wakefield	
12:45	NETWORKING LUNCH	
13:45	Session 3.01	Session 3.02
	DEVELOPING AN IT ROADMAP FOR WORKING FACILITY MANAGERS Professor Joachim Hohmann Technical University Kaiserslautern, Germany / Co-Founder & CEO, Consultants Circle, Frankfurt	JOURNEY TO A WORLD CLASS ORGANIZATION Mr Christopher Ahoy Consultant, Performance Management
14:35	Session 4.01	Session 4.02
	LEARNING FROM THE EXTREME: REDESIGNING MCMURDO STATION, ANTARCTICA Mr Rick Petersen FAIA, LEED AP	JTC'S ADOPTION OF SMART FM TO BETTER MANAGE ITS BUILDING AND ESTATES Mr Jason Foo Director, Building Management, JTC
15:20	AFTERNOON REFRESHMENTS	
15:50	Session 5.01	Session 5.02
	AUGMENTED INTELLIGENCE: AI AND THE FUTURE OF WORK Mrs Katie King Consultant, Zoodikers Consulting Ltd	ACTIVITY BASED WORKING Mrs Marlene Chandra Workspace Management Coordinator, BP Indonesia
16:40	Session 6.01	Session 6.02
	Township Management in Singapore: Sharing Professional Practices Mr Tony Khoo CEO, EM Services Pte Ltd / President, IFMA Singapore Chapter	OPERATIONALIZING TECHNOLOGY IN FACILITY SERVICES Mr Srinidhi Gopalakrishna Senior Vice-president, Technology Services, UEMS Solutions Pte Ltd
19:00	END OF DAY 1 CONFERENCE	
17:25	COCKTAIL NETWORKING RECEPTION	

Product Showcase & Solutions Arena

TIME	EVENT	
08:30	REGISTRATION OPENS	
09:00	POWER SPEAKER SESSION REAL ENDGAME OF IOT AND BIG DATA IN BUILDINGS: REAL USES AND SHORTCOMINGS OF UN-FOCUSED APPLICATION Mr Fulvio Bartolucci , General Manager, ADENERGY	
10:05	Session 7.01	
	ISO 41000: FM STANDARDS – KEY PRINCIPLES AND ITS IMPLEMENTATION Mr Stephen Ballesty , Director, In-Touch Advisory	
10:50	MORNING REFRESHMENTS	
11:30	Session 8.01	Session 8.02
	THE CONVERGENCE OF SMART CITIES, SMART BUILDINGS AND EMPLOYEE EXPERIENCES Mr John McGee , President, Archibus	THE IMPACT OF AI ON HIRING AND RETAINING WORKFORCE IN FM Ms Renske van der Heide , FM Strategy and Innovation Manager, Sensoria Pte Ltd/ TOPdesk Nederland BV
12:15	NETWORKING LUNCH	
13:15	Session 9.01	Session 9.02
	COMMISSION TO OPERATE (C2O) PLATFORM FOR SMART, GREEN BUILDING Mr Ashan Asmone , Doctoral candidate, National University of Singapore	STRATEGIC LIFE PLAN FOR FACILITY MANAGERS Mr Alex Lam , Chief Design Officer, Aviemore Stirling Inc
14:00	WORLD WORKPLACE ASIA STUDENT AWARD CATEGORY 2019 The Student Award category aims to hear from the young on potential ideas where technology can play a part in facilities management. The award will be the first facility management related competition open to the tertiary institutions. Students will present facility management solutions and systems that will help bring much convenience to the profession and its building occupants.	
	SPONSORED BY  <small>SMA – Your Partner in Facilities Management</small>	
15:00	AFTERNOON REFRESHMENTS	
15:30	TECH INNOVATION SESSION DIGITAL ENVIRONMENTAL ANALYTICS FOR FACILITY MANAGEMENT: DIGITAL TRENDS, TIPS, AND TOOL Mr Max Verteletskyi , CEO, Spaceti	
16:15	CLOSING KEYNOTE EMERGING TECHNOLOGIES & DIGITAL FUTURE: THE WORKPLACE OF THE FUTURE Mr Dmitri Chen , Chief Operating Officer, APJ and Vice President of Specialty Sales, Dell EMC	
17:00	CLOSING REMARKS Mr Graham Tier , Chair of IFMA's Global Board of Directors	
17:15	END OF DAY 2 CONFERENCE	
17:15	PRIVATE EVENT (by invitation) HOSTED BY 	

Product Showcase & Solutions Arena

FM TRENDS AND BEST PRACTICES IN TIMES OF DIGITAL DISRUPTION: A GLOBAL PERSPECTIVE

The conference commences with a plenary session by prominent international and local industry experts. Gain valuable insights from this session through a series of sharing and panel discussion on the global perspective of the FM emerging trend and best practices in the midst of digital disruption.

PLENARY MODERATOR



TONY KHOO
*Chief Executive Officer, EM Services
President, IFMA Singapore Chapter*

Tony has over 30 years' wealth of experience in property industry covering design, project management, development management, investment and feasibility study, property facility township management, and marketing and leasing. He is currently the CEO of EM Services Pte Ltd, which is the market leader in township management in Singapore managing over 700,000 Housing Development Board residential units.

As the current President of International Facilities Management Association (IFMA) in Singapore, Tony is active in promoting and developing facilities management as a rewarding, fulfilling and recognized profession in the real estate world. He is also the co-Chair of the FM Implementation Committee to drive transformation in the industry under the Real estate ITM (Industry Transformation Map).



GRAHAM TIER
*CFM, MRICS
Chair,
IFMA's Global Board of Directors*

Graham Tier, CFM, MRICS, currently serves as head of facility management with The Hong Kong Jockey Club (HKJC). Tier has more than 20 years of experience in operations and maintenance for leading international companies including British American Tobacco, Johnson & Johnson, McPherson's and Amcor, and shares a network with many blue chip organisations internationally.

As an ambassador of FM best practices and innovation in Asia, he has transformed facility services across all segments of the HKJC property portfolio, including introducing asset health policies and procedures, FM-enabling technology and new forms of FM contracts.



ANG KIAN SENG
*Group Director,
Environmental Sustainability
Group, Building and
Construction Authority,
Singapore*

BCA's mission is to shape a safe, high quality, sustainable and friendly built environment. The Environmental Sustainability Group initiates and implements policies and measures to enhance the sustainability of the built environment.

As Group Director of the Environmental Sustainability Group, Kian Seng oversees the BCA Green Mark Scheme which certifies buildings on their level of environmental friendliness and energy efficiency. Kian Seng plays an instrumental role in the formulation and implementation of BCA's 3rd Green Masterplan, with the long term goal of greening 80% of Singapore's buildings by 2030. Kian Seng is the 2nd Vice President of the Singapore Green Building Council.



KENNETH FOO
*Executive Director,
Hongkong Land
Limited*

Kenneth Foo was appointed Executive Director of Hongkong Land Limited on 1st January 2016, overseeing all the Company's property management activities. He was previously Head of Building Operations, Property Management.

Mr Foo has extensive experience in property management and engineering services. Throughout his career he has served as a consultant and project manager for contractors and developers in New Zealand, Indonesia, Thailand and Singapore. He is Past President of the International Facilities Management Association (Singapore Chapter) and a member of the Technical Consultative Panel of the BCA (Building and Construction Authority).



JEFFREY BUDIMULIA
*CFM, IFMA Fellow
Director, CRE Advisers
Pte Ltd & Past Director,
Board of Directors of
IFMA*

Jeffrey has 30 years of experience in the FM Industry. He started his FM career in the semiconductor industry and was responsible for the FM business in Asia Pacific for a client. Jeffrey was one of the founder members of IFMA Singapore Chapter, involved in the Start-up of the Beijing Chapter and also a member of the IFMA Board of Directors for 2 years. He is currently in China. Today, Jeffrey is involved in the "giving back" phase of his career where he conducts training sessions and mentoring others, aside from providing FM consultancy services.



STEPHEN BALLESTY
*IFMA Fellow
Director,
In-Touch Advisory*

Stephen Ballesty is an award winning local and international industry leader. His consulting firm In-Touch Advisory connects stakeholders with solutions for the Built Environment across the property–construction–facilities life cycle.

He is currently an Australian delegate for the ISO international FM standards initiative (ISO 41000 since 2012), ISO/TC267's global liaison to ISO/TC-251 (ISO 55000 asset management). He is the former member of the IFMA Board of Directors and Past Chairman of both the IFMA Foundation; and FMA Australia. Stephen has been the Property Council of Australia's Building Quality Steering Committee chairman for the past 14 years. In 2018, he became the first recipient in the Oceania region of an IFMA Fellowship.

2.01

12:00pm

CRE/FM Market Trends in APAC – Service Providers on the Spot

SESSION DESCRIPTION

This lively interactive session will discuss the findings of a recently published Trascient APAC Market Report, assessing the current issues and trends in the regional market from both an end user and service provider perspective. The panel will be asked to delve into key points, with audience input to develop the discussion.

Anticipated discussion topics includes:

- Forecast the evolution of services – how is the market changing?
- Will technology really revolutionize the fundamentals of CRE/FM?
- Is there a market disruptor coming?
- What is the good and the bad of current CRE/FM outsourcing/contracting in APAC?
- How can the outsource process be improved to maximize results for both parties?
- What are the characteristics of a good client?
- Are APAC headquartered companies' requirements different from global MNCs?
- Are there any new entrants? Are APAC companies changing the global CRE market?
- Key concerns and challenges operating in APAC from the SP perspective
- How do the major service providers vary?

LEARNING OBJECTIVES

- Learn the practical information from regional leaders about market practice to apply into current and future outsourcing relationships, for attendees either as end users or service providers.
- Gain perspective on the current big issues and forecast macro trends for CRE/FM in APAC.
- Understand how Chinese and APAC companies are affecting the CRE market in region and globally.



SPEAKERS

MARK HUNTER *International Director – Account Management, Jones Lang LaSalle*

Mark is the International Director - Account Management and has oversight of a number of JLL's regional IFM and multi-disciplinary accounts.

He is also the APAC CRM for a number of client accounts which are multi-regional and multi-disciplinary. He was previously the Account Director for the Citigroup, Deutsche Bank and Sun Microsystems accounts. In these roles he has overseen the delivery of transaction, project and facility management, lease administration and space data and occupancy planning services across the region. Mark has held a number of other positions during his nearly 20 years with JLL including the Asia Pacific Head of Lease Administration and the Country Director for the Integrated Facilities Management businesses in Korea and Taiwan.



ABEL ARIZA *Head, APAC Strategic Accounts, FMCG, Sodexo in Asia Pacific*

Abel has more than 15 years' experience in FM international account management. Abel joined ISS in 2003 and led the Corporate Clients transformation journey at group level. He was

instrumental to win ISS' first Global Contract with HP in 2006 and subsequent EDS extension after the acquisition in 2008. He joined Sodexo in 2012 as the Regional Lead in south Europe for Unilever. In 2016, he moved to Asia to grow the FMCG expertise in the region. Abel is a private aircraft pilot, Naval Engineer and MSc Market Research. Holds an INSEAD MBA.



MIKE RUNICLES *Chief Operating Officer, Global Workplace Solutions, APAC, CBRE*

Mike leads Global Workplace Solutions (GWS) business with 12,000 staff serving clients in 21 countries across Asia Pacific, providing Facility Management, Project Management, Advisory and Transaction Services. Mike has been instrumental in the development of Global Workplace Solutions (GWS) for 28 years, and has worked with customers across all sectors and regions. Previous positions include the development and leadership of Global Markets for the Technology and Industrial sectors.



ANDREW SCOTT DALE *Director, Global Occupier Services, Cushman & Wakefield*

A highly motivated and experienced commercial finance manager with over 12 years' experience in corporate finance, business partnering, client finance, property, facilities and capital works fields, as well as

currently being the commercial lead for key wins for the C&W business. Andrew has a deep understanding and experience in the FM/Property industry and has successfully implemented new ERP/FM systems for C&W throughout the APAC region.

3.01

1:45pm

Developing an IT Roadmap for Working Facility Managers

SESSION DESCRIPTION

Organizations of all sizes are faced with both the fundamentals of optimizing the technology they utilize to effectively operate their facilities. Furthermore, the marketplace is moving at a rapid pace with the introduction of new hardware and software solutions which are promised to provide operational improvements.

This session will answer to many organizations' questions such as:

- Do we have the right solutions in place?
- Are our current solutions correctly interfaced/integrated?
- How do we perform an effective audit?
- How do most effectively benchmark? What should we be benchmarking?
- How do we develop a realistic GAP Analysis?
- Once the facts are in, how do we develop a road map?

LEARNING OBJECTIVES

- Know how to conduct a FM Technology System Inventory
- Define the value of a Technology and Data Audit
- How to best prepare for developing a sustainable IT Roadmap for Facility Operations



SPEAKER

PROF JOACHIM HOHMANN *Technical University Kaiserslautern, Germany*

Co-Founder & CEO, Consultants Circle, Frankfurt

Joachim Hohmann, CFM, Ph.D., MSc is a professor teaching facility management technology at the

Technical University Kaiserslautern, Germany. As a co-founder and CEO of Consultants Circle in Frankfurt, he provides consultancy in facility management strategy and technology to a wide range of organizations. He served on IFMA's Board of Directors from 2010 to 2013 and represented IFMA on the Board of Directors of Global FM, Melbourne, Australia. As an active member of the IFMA IT Community of Practice (ITC), he represents Europe in their Global Leadership Team. In 2018, he was named IFMA Fellow, the highest honor members can earn within the association.

3.02

1:45pm

Journey to a World Class Organization

SESSION DESCRIPTION

With the new paradigm shift in the world with the advent of CRISPR/Cas9, an RNA-guided targeted genome-editing tool – which allows researchers to do gene knockout, knocking SNPs, insertions and deletions in cell lines and animals. The future portends to be closer to the “Brave New World,” we all have been talking about and expecting things to change for the benefit of human kind where there is access to better healthier life.

With the possibility of gene editing for improvements in life, we can draw parallels of ‘editing’ FM practices for the better looking at existing successful FM organizations practices. ‘Journey to a world-class organization’ is an aspiration in any facilities management organization to reach to ‘Become the Best of the Best’. Hence, the conference theme, ‘Building the Future of Facility Management through Digital Innovation’ is part of a holistic system that requires a solid FM organization where there are efficient operations in an effective organization. Leadership must focus on building self-equity and organizational equity in the five areas of People, Machines, Materials, Method and Environment.

LEARNING OBJECTIVES

- Showcase a successful world-class stature using quality tools
- Know the tools require to achieve organisational objectives



SPEAKER

CHRISTOPHER AHOY *Consultant, Performance Management*

Christopher K. Ahoy, Emeritus APPA President 2006, retired in 2010 as the Emeritus Associate Vice President of Facilities Planning and Management

at Iowa State University. An internationally recognized expert on quality initiative and has presented creating a world-class organization in South Africa, Singapore, Australia, New Zealand, Ireland, the United Kingdom, Mexico, and US. He was responsible for having his organization become five times recipient of the state of Iowa’s annual Recognition for

Performance Excellence Award, and the final Gold Achievement Award in 2009.

He is a mentor (currently mentoring five students from UC Berkeley and one from San Francisco State University and three international adult facilities management professionals and one HR professional), a coach, a presenter and an author of 5 books.

4.01

2:35pm

Learning From The Extreme: Redesigning McMurdo Station, Antarctica

SESSION DESCRIPTION

McMurdo Station, Antarctica is the primary hub to support the National Science Foundation’s activities on the Antarctic continent, the coldest, driest and windiest on Earth. McMurdo began in 1955 as a military outpost and has grown haphazardly to over 100 buildings scattered over 250 hectares. As a result, the station poses challenges with respect to logistical and energy inefficiencies, as well as quality of life. The station was redesigned with an emphasis on issues related to Facilities Management.

LEARNING OBJECTIVES

- Describe the strategies for improving efficiency, wellness and safety
- Know the various site planning strategies, building envelope design, interior finishes for maintenance, and digital controls of lighting and energy use
- Learn to apply the process and strategies of designing at the extreme



SPEAKER

RICK PETERSEN FAIA, LEED AP *Principal, OZ Architecture*

As a Principal with OZ Architecture, Rick Petersen leads a wide range of design projects that benefit from collaboration among highly diverse stakeholders, whether in his home town of Denver or in Antarctica, where he led the redesign of McMurdo Station for the National Science Foundation. His work yields resource-efficient communities that promote well-being, including transit-oriented development (TOD), workforce housing, corporate office, higher education, adaptive re-use and a wide range of cultural facilities.

Rick received his Master of Architecture from Harvard University and BA in Environmental Design from the University of California, Berkeley. Rick has been an adjunct faculty member at the University of Colorado College of Architecture and Urban Planning, and he serves on boards of the Leukemia & Lymphoma Society and the Denver Architecture Foundation. In 2018, Rick was elevated to the College of Fellows of the American Institute of Architects for his promotion of interdisciplinary collaboration, his civic leadership, and his commitment to educating and inspiring future architects.

4.02

2:35pm

JTC'S Adoption of Smart FM to better manage its building and Estates

SESSION DESCRIPTION

JTC transformed the way it managed its buildings and estates by streamlining processes, upskilling its people and leveraging technology, in response to challenges in the existing FM industry and to address changes in the FM landscape.

Smart FM technologies have disrupted the playing field in areas such as digitalisation of assets and automation of workflow. This has presented JTC with opportunities to use Big Data for systems analysis and diagnosis to improve and streamline future FM endeavours.

LEARNING OBJECTIVES

- Understand how the Building Optimisation System allows FM optimisation in JTC
- Gain methods of other smart FM solutions it has developed, adopted or test-bedded, such as the estate monitoring system, the workflow automation system, smart bins, cleaning robots and lift monitoring systems.



SPEAKER

JASON FOO *Director, Building Management, JTC*

Jason Foo is the Director of the Building Management Division in JTC Corporation (JTC), the lead government agency responsible for the planning and development of industrial infrastructure to support and catalyse the growth of industries and enterprises in Singapore. In his current role, Jason oversees facilities management (FM) operations for all buildings. To transform FM for JTC, he drove many new initiatives, including a Tenant Engagement Framework to promote co-ownership of FM, the alignment of FM SOPs for all JTC developments, and the tracking of sustainability performance for all buildings. Furthermore, Jason played a key role in the digitalisation of JTC's FM operations.

Beyond spearheading innovative projects such as Comfy, he also successfully led the implementation of the Building Optimisation System, a cloud-based integrated smart estate and building operations system, across 39 JTC buildings.

5.01

3:50pm

Augmented Intelligence: AI and The Future of Work

SESSION DESCRIPTION

As Artificial Intelligence (AI) transforms our healthcare and robots begin serving our food and cleaning our homes, Katie King examines the future impact of AI on the workforce. Today, AI can automate repetitive, standardised or time-consuming tasks, providing what PwC labels 'assisted intelligence.' The AI which is emerging could be described as augmented intelligence, and it could fundamentally change the nature of work. It will see humans and machines collaborate to make decisions. Emotional intelligence, creativity, persuasion, innovation therefore become the more valuable, unique human traits. Ultimately, we could face a world where adaptive continuous intelligent systems take over decision-making, which brings into question the future of humans in the workplace. This is known as autonomous intelligence.

LEARNING OBJECTIVES

- The new AI paradigm
- What are the innovation and change management?
- The strategy and preparedness of applying AI to your business



SPEAKER

KATIE KING *Consultant, Zoodikers Consulting Ltd*

Katie King is a published author, TEDx/Keynote Speaker, as well as a trainer and consultant. Her book, on the impact of AI in Marketing, will be published in February 2019 by publisher Kogan Page. It features FM companies such as JLL. Katie is the Co-Founder of AI in FM, and co-authored an AI white paper for RICS. She has spoken at EFMC Berlin, at RICS' events, and will feature on the panel at the RICS' Harris debate in November. Katie frequently delivers "AI in Business Growth" training courses globally too. During her 28-year career, Katie has advised and trained global brands including ISS, Mitie, M&S, Sky, Harrods, o2, Virgin, Arsenal Football Club, NatWest and many more.

5.02

3:50pm

Activity Based Working

SESSION DESCRIPTION

In support of BP Indonesia's long-term office accommodation strategy, an Activity Based Working (ABW) was adopted to maximize office space utilization and improve work environment. The ABW concept helps optimize workspaces by letting users choose the space best suited for their purposes. ABW is an approach to work that does not require a traditional office, but a 'hybrid environment' that provides a place for people with shared amenities and spaces and effectively changing a mind-set of my space to be our space.

LEARNING OBJECTIVES

- Understand the Activity Based Working concept
- Discuss the opportunities and its values
- Discuss the ways to rethink the work contribution to Activity Based Working



SPEAKER

MARLENE CHANDRA *Workspace Management Coordinator, BP Indonesia*

Marlene Chandra is the Workspace Management Coordinator at BP Berau, Ltd. During her 9-year tenure, she manages office operations which leads to office improvement with cost efficiency and safety principle. Before this role, she was involved in various interior design and project management for office, retail and shopping centre in Indonesia.

6.01

4:40pm

Township Management in Singapore: Sharing Professional Practices

SESSION DESCRIPTION

Tony has recently co-authored a book on "Township Management in Singapore: Sharing Professional Practices". In this presentation, he will

share the ten key business functions and their respective processes of managing a township. He will also discuss the motivation behind writing this book, the challenges he faced and how he overcome them.

LEARNING OBJECTIVES

- Singapore is renowned for her world class public housing which are organized into townships. Delegates will have insights of how these townships are structured and managed in Singapore.
- Delegates will also learn about the 14 desired outcomes, 10 key business functions and 84 key processes of managing successful townships.
- The speaker will share the methodology behind this framework so as delegates can readily adopt it for their own FM practices.



SPEAKER

TONY KHOO *Chief Executive Officer, EM Services | President, IFMA Singapore Chapter*

Tony has over 25 years' wealth of experience in property industry covering design, project management, development management, investment and feasibility study, property facility township management, and marketing and leasing.

As the current President of International Facilities Management Association (IFMA) in Singapore, Tony is active in promoting and developing facilities management as a rewarding, fulfilling and recognized profession in the real estate world. Tony has recently co-authored a book on "Township Management in Singapore: Sharing Professional Practices". In this presentation, he will share the ten key business functions and their respective processes of managing a township. He will also discuss the motivation behind writing this book, the challenges he faced and how he overcome them.

6.02 4:40pm
Operationalizing Technology in Facility Services

SESSION DESCRIPTION

Today with more smart buildings around there are a whole of technology used across these buildings such as BAS/BMS systems. In the recent years, buildings are incorporating IoT, Analytics and robotics into the building performance and monitoring system. But how does this impact the facility management team maintaining our buildings? Are the FM personnel ready to adopt these new age technology? What technologies are available? Moving forward, what do the FM personnel require to manage and maintain the building effectively?

LEARNING OBJECTIVES

- Know the new age technologies available and the impact to FM personnel
- Learn the new "Pay to perform" model of contracting

SPEAKER

SRINIDHI GOPALAKRISHNA *Senior Vice-President, Technology Services, UEMS Solutions Pte Ltd*

Srinidhi Gopalakrishna is currently the Vice-president of Technology Services for UEMS Group. With more than 19 years of experience in technology development, he has been with the UEMS Group for more than 13 years developing innovative products that are presently offered as part of their UETrack™ suite. He has been instrumental in managing several business transition programs that involved the adoption of technology into healthcare support services. Prior to this, Srinidhi

worked in India as project manager for a US based company where he has acquired experience in the field of Digital Media and Enterprise Software Development.

DAY 2 CONFERENCE PROGRAMME

POWER SPEAKER SESSION

9:00am

How SMART is smart? Going beyond buzzwords with IoT and big data

SESSION DESCRIPTION

Internet of Things (IoT) and big data made significant impact across various communities in today's world. Organizational culture affects IoT and big data projects success more than technology. It is important to understand the meaning of building data and what are the obstacles of obtaining such data. Understanding how the changes could be brought into the system and improvement could be achieved.

Fulvio will share in his presentation,

- What we should expect and strive for, with IoT and big-data for facility management
- An understanding of what is situational awareness in the built environment and conscious building, what contributes to get an organization there and what gets it derailed on the way
- How building on situation awareness, IoT to delivers flexibility to deal with a changing environment
- System-human interface to retain a key role in the definition of objectives and decision making
- How optimization practices in internet are growingly influencing the connected and data-driven building management

LEARNING OBJECTIVES

- Understand what it takes to obtain meaning from building data and what are the obstacles to it
- Learn the method how change is brought into the system and improvement achieved
- Learn that organizational culture affects IoT/big data projects success more than technology



SPEAKER

FULVIO BARTOLUCCI *General Manager, ADENERGY*

Fulvio has spent nearly two decades developing solutions for sustainable energy projects across Europe and the Asia-Pacific region. Beginning as an environmental strategy consultant, Fulvio was inspired by early field work in Cambodia and Bangladesh to create a microfinance and sustainability start-up.

Fulvio has been actively focused low-carbon, renewable and energy efficiency projects in Asia's renewable industry since 2007. Before becoming a co-founder of ADENERGY, Fulvio served as General Manager and Director of Business Development for a major European energy company. Besides his renewable energy leadership, Fulvio is also highly active in Asia's SMART building and SMART city movement.

7.01

10:05am

ISO 41000: FM Standards - Key Principles and its Implementationupdate

SESSION DESCRIPTION

The release in 2017 of the first ISO 41000 suite of international Facility Management (FM) demonstrates how standards can contribute to a more productive, sustainable and livable built environment which influences our Quality of Life. As FM standards provide a common language and a framework to support global consistency in the delivery of services, fine-tune performance and manage risks while allowing businesses to operate in a more effective, efficient and resilient manner. In April 2018, the 'ISO 41001:2018 FM Management System Standard – Requirements with guidance for use' was introduced.

LEARNING OBJECTIVES

- Know the leadership and culture issues surrounding ISO 41000
- Understand the impact of standards on managing our Built Environment



SPEAKER

STEPHEN BALLESTY IFMA Fellow *Director, In-Touch Advisory*

Stephen Ballesty is an award winning local and international industry leader. His consulting firm In-Touch Advisory connects stakeholders with

solutions for the Built Environment across the property–construction–facilities life cycle.

He is currently an Australian delegate for the ISO international FM standards initiative (ISO 41000 since 2012), ISO/TC267's global liaison to ISO/TC-251 (ISO 55000 asset management). He is the former member of the IFMA Board of Directors and Past Chairman of both the IFMA Foundation; and FMA Australia. Stephen has been the Property Council of Australia's Building Quality Steering Committee chairman for the past 14 years. In 2018, he became the first recipient in the Oceania region of an IFMA Fellowship.

8.01

11:30am

The Convergence of Smart Cities, Smart Buildings and Employee Experiences

SESSION DESCRIPTION

The Facility Manager's role is rapidly evolving from managing building operational costs and assets to managing all of the drivers that optimizes individual, team, enterprise and Employee Experience (EX) in buildings. This change of role will move Facility Management and the Facility Manager from important operational roles to key strategic roles as businesses emphasize Employee Experience as the key focus to attract, motivate and retain employees.

Future smart buildings will continuously adapt to users in order to provide the work environment that maximizes employee and team effectiveness. Smart buildings have become an integral component of smart cities that delivers 24-hour individualized, adaptive environments for city occupants and building employees.

In the "Sustainability" era, traction did not happen until there were direct ties to company bottom-lines. And that was provided by the financial returns coming from energy efficiency and energy demand initiatives IoT and Big Data promises are at the same stage as the early-sustainability era.

LEARNING OBJECTIVES

- Learn the future of Smart City and Smart Building initiatives from a unique perspective – their ability to leverage Employee Experience (EX) to advance smart initiatives
- Know what are the impact of 'Smart EX' programs



SPEAKER

JOHN MCGEE *President, Archibus*

John McGee is the President of ARCHIBUS, Inc. John has vast experience in technical, operational, and general management of commercial, industrial, energy sectors. He is experienced in managing product lines and business units from development through commercialization and structuring operations for standardization and scalability. He had developed and executed successful plans for industrial, commercial, government, regulated, OEM and wholesale customers. Currently John served as Chairman of the Board of the International Facilities Management Association (IFMA).

8.02

11:30am

The impact of AI on hiring and retaining workforce in FM

SESSION DESCRIPTION

Great knowledge management is the backbone of successful applications of AI Utilizing methods like Knowledge Centered Support and Best Practice Knowledge Management will provide the foundation for success. At TOPdesk, it was recently implemented the first Machine Learning functionality in a services architecture. The functionality categorizes an incoming call automatically based on the contents of the request field and in real-time to free up time for the service desk operator. This helps operators, particularly inexperienced operators, register calls more quickly and immediately gain the benefits of categorization for follow-up. AI is here to make sure your organisation runs smoother, with a higher quality of service and impeccable customer experience. With AI, you can improve your processes, grow your teams' skills and deliver better services.

LEARNING OBJECTIVES

- What does Artificial Intelligence mean for the way we do our work in FM
- Better Service Management with Artificial Intelligence



SPEAKER

RENKE VAN DER HEIDE *Product Manager / FM Strategy and Innovation Manager, TOPdesk Nederland BV*

Renske van der Heide is from the Netherlands and works at TOPdesk for over ten years. She has held various positions, including that of facility consultant and team leader consultancy. As an initiator of TOPdesk GO she's leading TOPdesks efforts for a collaboration platform for better communication between suppliers, the facility management team and customers of a service. Renske is board member of EuroFM, that brings educators, researchers and practitioners in the field of Facility Management together. Renske is also part of the Technology and Innovation Expert Group of Facility Management Netherlands (FMN), which examines the impact of trends such as Big Data and the Internet-of-Things.



HARI GUNASINGHAM *CEO, Eutech Cybernetic Pte. Ltd*

Hari Gunasingham is the founder of Eutech Cybernetic. He authored over 60 internationally refereed research papers and co-inventor of several patents. Dr Gunasingham obtained First Class Hons Degree and PhD from the Imperial College and Science, Technology and Medicine in the area of Analytical Science. He worked for British Petroleum and taught at the National University of Singapore for ten years before founding Eutech Cybernetic. Initially, Eutech focused on developing instrumentation and control products. This was a successful global business that he spun off and sold to Thermo Fischer in 2000 to focus on developing software-driven technology for Smart Buildings and Healthcare.



KASUN RILLAGODAGE *Project Manager, Eutech Cybernetic Pte. Ltd*

Kasun is a project manager with Eutech Cybernetic Pte Ltd with many years of experience in deploying IBMS and smart workplace management systems.

9.01

1:15pm

Commission to Operate (C2O) Platform for Smart, Green Buildings

SESSION DESCRIPTION

Smart, green buildings improve building efficiency operations and maintenance, as well as enhance tenant productivity, and comfort whilst providing a more sustainable built environment. Proper operation of smart, green buildings is dictated by proper commissioning of the building systems. Commission to Operate (C2O), is a first of its kind automated workplace management system developed to manage smart buildings from design, commissioning to operations and maintenance.

C2O leverages on Building Information Modelling (BIM) and Internet of Things (IoT) technology to provide an integrated framework for information management and data exchange. This approach transforms the conventional CAD-based BIM into model of systems and processes for commissioning, operations and maintenance.

LEARNING OBJECTIVES

- Understand how the Commission to Operate platform enabling the FM professionals in day-to-day operation
- Learn the ways to leverage on IoT in FM practices



SPEAKERS

ASHAN ASMONE *Doctoral candidate, National University of Singapore*

Ashan Asmone is a doctoral candidate attached to the School of Design and Environment at the National University of Singapore who has majored in facilities management and holds a Master's in environmental management. He has years of experience in building-related research in sustainability and maintainability and has several publications under his name. Ashan's experience prior to joining the NUS maintainability research group as a research scholar includes work experience in the facilities management industry, and as a lecturer in academia.

9.02

1:15pm

Strategic Life Plan for Facility Managers

SESSION DESCRIPTION

In recent years, the study of gerontology has produced massive literature and research findings about how to age and how to prevent the development of life-burden illnesses. According to the US National Institute of Neurological Disorder and Stroke, dementia is not a normal part of the aging process. We must not allow aging to catch us by surprise. Much like our FM preventive maintenance program, we all should prepare a preventive strategy for ourselves so that we can age successfully.

LEARNING OBJECTIVES

- Know the reality of aging and how you can use your FM skills to prepare a strategic life plan
- Learn the new age of theories – the telomere effect



SPEAKER

ALEX LAM *Chief Design Officer, Avimore Stirling Inc*

Alex Lam is the Chief Design Officer with AVIEMORE STIRLING in Toronto planning orphanages for third world countries. With over 50 years in the industry, his career includes over 23 years as GM - Facilities with Bell Canada and had taught graduate level master classes on design, leadership, and facility management at The University of Hong Kong, The University of Manitoba and Ryerson University in Canada. A frequent speaker at international conferences, his recent talks include 2018 WWP China in Beijing on The Aging Facility Manager, 2017 WWP Europe in Stockholm on Work on the Move 2; 2016 FM Summit in New Zealand on The Humanity in FM. He was elected IFMA Fellow in 2011 and Fellow of HKIFM in 2004.

TECH INNOVATION SESSION 3:30pm
Digital Environmental Analytics for Facility Management: Digital Trends, Tips, and Tool

SESSION DESCRIPTION

Firms are continuing to evolve, placing more strategic importance on the wellbeing of their employees, especially in light of the demands made by a new generation that expects the same accessibility to technology in their work and private lives. How do you adopt long-term digital tools like air quality controls or occupancy analysis to improve the indoor environment, productivity, and wellbeing, all while reducing operating costs?

LEARNING OBJECTIVES

- Know the benefits from making buildings digital of different stakeholders – tenants, property managers and building owners
- Sharing of case studies from MSD, Cushman & Wakefield, Škoda, Sodexo

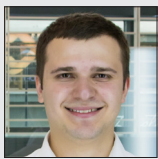

SPEAKERS

MAX VERETELETSKYI *Chief Executive Officer, Spaceti*

Max was born in Ukraine and is the youngest Innovation Lab Leader at the age of 21. Max was also an active technology mentor within the startup ecosystem, and he was inspired by the spirit of entrepreneurship he encountered.

Max founded Spaceti, a company that digitises buildings and improvise the office better through a combination of smart environment and occupancy sensors, a data analytics platform, and an interface in a mobile app. Its mission is to make a positive impact on wellbeing and productivity in office environments and it has the ambition to become a global unicorn within the next three years. Max's long-term personal vision is to make a positive impact on more than 1 billion people using the power of technology, investments into healthcare and research, and through philanthropy.

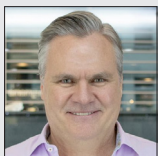

MAGNUS ÅKERBERG *Commercial Director, Spaceti*

Magnus is a dedicated leader and proven senior level executive with significant strategic and operational global experience in complex B2B environments.

He is result oriented, collaborative and influencing, customer and team focused with strong relationship and networking skills. Magnus is Chairman and Co-Founder for Akerberg Thomas and CEO, Founder and Senior Advisor for Agermons AB and has previously held leading positions within JLL, ISS, Johnson Controls, and Serco. Finally, Magnus works as the Commercial Director at Spaceti.

CLOSING KEYNOTE 4:15pm
Emerging Technologies & Digital Future: The Workplace of the Future

SESSION DESCRIPTION

Digital future is imminently approaching, enabled by developments in Artificial Intelligence (AI), Internet of Things (IOT), robotics, 5G, Virtual and Augmented Reality, etc. Every industry and organization is facing a dilemma on how to survive and thrive in this new market. A number of new business, process, technology, and partnering adjustments are required to make it in this new world.

LEARNING OBJECTIVES

- Highlight some of the emerging technologies, the impact they are making on the future of workplace
- How to best prepare for the opportunities and challenges they bring.



SPEAKER

DMITRI CHEN *Chief Operating Officer, APJ and Vice President of Specialty Sales, Dell EMC*

Dmitri Chen is Chief Operating Officer and Vice President of Specialty Sales for Asia Pacific and Japan (APJ) at Dell EMC Corporation. He has more than 22 years of industry experience in information management software, hardware and sales and services. Since joining Dell EMC in March 2000, Dmitri has held roles in Global Accounts, Sales Leadership, Chief of Staff Americas Sales and most recently Vice President of Sales for Data Protection and Availability for APJ. He is based at Dell EMC's APJ headquarters in Singapore and reports to David Webster, Dell EMC's Enterprise President for APJ.

World Workplace Asia
STUDENTS AWARD
CATEGORY 2019

The Student Award category aims to hear from the young on potential ideas where technology can play a part in facilities management. The award will be the first facility management related competition open to the tertiary institutions. Students will present a facility management solutions and systems that will help bring much convenience to the profession and its building occupants.

Sponsored by

Sj **SURBANA**
JURONG
SMM – Your Partner in Facilities Management

COCKTAIL NETWORKING RECEPTION & CONFERENCE VENUE



Marina Bay Sands, Singapore Level 3, foyer outside Jasmine Ballroom

Join us for cocktail networking reception amongst the hosts, speakers and fellow delegates to share experiences from the conference and solidify connections made at the event. The cocktail networking reception, served with delightful canapies, wine and cheese would be a perfect session to end the day of learning and networking.



MARINA BAY SANDS, SINGAPORE

Marina Bay Sands is the leading business, leisure and entertainment destination in Asia. It features large and flexible convention and exhibition facilities, 2,561 hotel rooms and suites, the rooftop Sands SkyPark, world's largest and highest rooftop swimming pool, the best shopping mall in Asia, world-class celebrity chef restaurants and an outdoor event plaza. Its two theatres showcase a range of leading entertainment performances including world-renowned Broadway shows. Completing the line-up of attractions is ArtScience Museum at Marina Bay Sands which plays host to permanent and marquee exhibitions.

BALLROOM LAYOUT

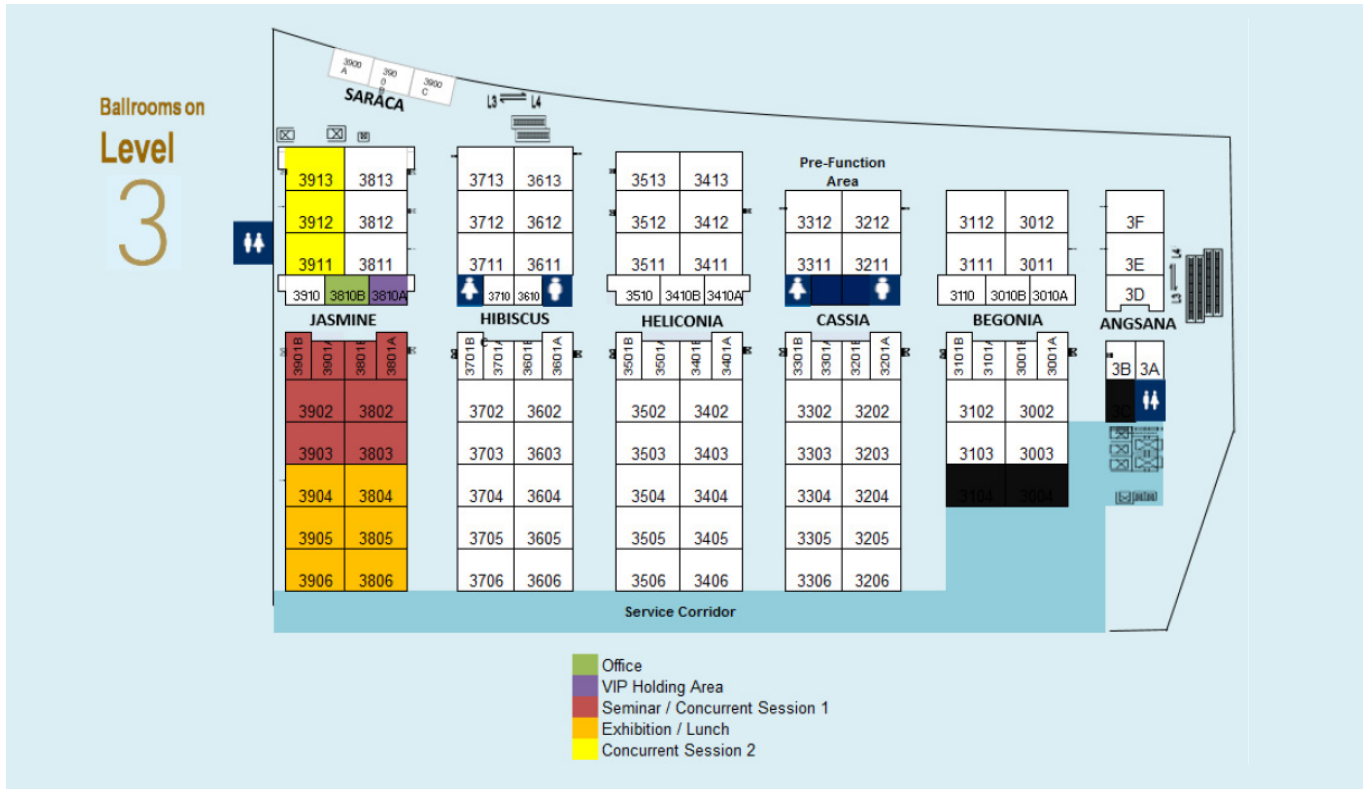

EXHIBITION FLOOR PLAN

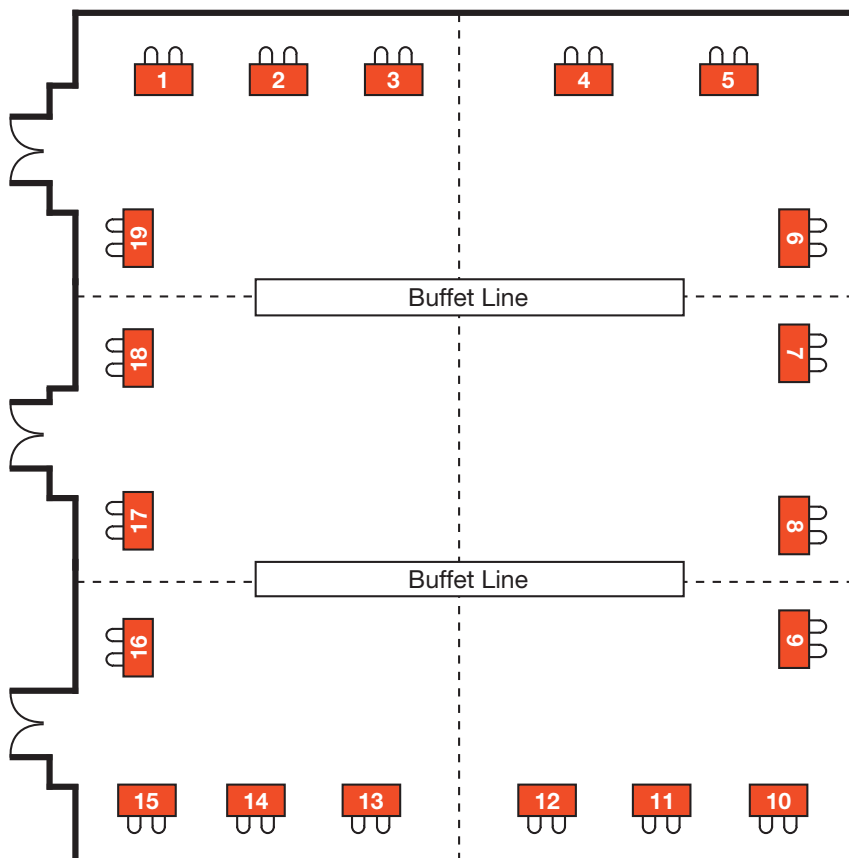

JASMINE BALLROOM

- 1 Schneider Electric
- 2 Serraview
- 3 FaMe-Online
- 4 Aden Group
- 5 Aden Group
- 6 Conference & Exhibition Management Services Pte Ltd
- 7 Sensorla Pte Ltd
- 8 Planon Asia Pte Ltd
- 9 Digital Lumens
- 10 Delta Energy Ent Pte Ltd
- 11 FSI (FM Solutions) Limited
- 12 EM Services Pte Ltd
- 13 IFMA
- 14 BCA Academy
- 15 e2i
- 16 Jardine Engineering (Singapore) Pte Ltd
- 17 UEMS Solutions Pte Ltd
- 18 C&W Services Pte Ltd
- 19 Dell EMC

TRACK 1



Schneider Electric Office

Schneider Electric East Asia & Japan Headquarters in Singapore is a model of digital transformation for future-proof, energy efficient and sustainable building. This 20-year-old building is retrofitted by Schneider Electric's own EcoStruxure solution, which include Connected Products, Edge Control and 7 Advisors, including Building, Power, Resource, Asset, Facility, IT and MicroGrid.

Find out more about predictive analytics and how a building owner can enjoy better energy management, reduced cost and energy wastage. Experience real life demonstration on how Schneider Electric's building lives and breathes its own technology.

TRACK 2

Singapore District Cooling Plant



The Singapore District Cooling Plant having a total plant capacity of 62,000 RT, operates one of the world's most efficient district cooling network serving the premium Marina Bay business district. The plant was featured as one of the top engineering feats by the Institute of Engineers Singapore in 2016.

JTC Summit J-Ops Command Centre



JTC's J-Ops Command Centre is one of the first integrated building and estate operations command centres in Singapore. It houses multiple smart Facilities Management (FM) systems with functions such as building optimisation, estate monitoring and workflow automation, to allow JTC to remotely monitor and manage FM operations for majority of its buildings and estates across the island. Located in the JTC Summit, the Command Centre allows JTC to achieve improvements in tenant comfort, reductions in energy leakages, and efficiencies in resource deployment.

TRACK 3



Marina Bay Financial Centre Tower 3

Marina Bay Financial Centre Tower 3 is conferred the BCA Green Mark Platinum Award. Managed by Raffles Quay Asset Management, the building leverages on digitalization and technologies to manage the building performance system.



Certis Commonwealth

Certis Commonwealth is a user-centred, open innovation ecosystem based on a systematic user co-creation approach. It serves as a Living Lab where new technology is operationalised in a "live" environment. Built on a 'Digital Twin' framework, it is designed to improve operational efficiency, drive process optimisation and enhance service excellence through the convergence of the physical and digital worlds.

TRACK PARTNER**Singapore University of Social Sciences**

The Singapore University of Social Sciences (SUSS) is an autonomous university with a rich heritage in providing lifelong, learner-centric and industry-relevant education. SUSS offer more than 70 undergraduate and graduate programmes, available in full- and part-time study modes which are flexible, modular and multi-faceted in learning experience to cater to both fresh school leavers and adult learners. The University also launched a broad range of continuing education and training modular courses for the professional skills and knowledge upgrading of our workforce.



Tel : +65 6248 0188
Email : uc@suss.edu.sg
Website : www.suss.edu.sg

PLATINUM SPONSOR**Aden Group**

Asia has changed. Asia has evolved. So have the needs of businesses in an economy 4.0 where strategic deployment of SMART tech, clean energy, AI and automated solutions is a must-have for ongoing competitiveness. More than any integrated facility management (IFM) provider, ADEN recognizes that the new era has already arrived and puts the next wave of SMART tech and data tools at the heart of our solutions.

ADEN is Asia-born and Asia-centric, with a 20 years history of getting things done in China, ASEAN and beyond. ADEN has built a powerful network and is headquartered in Shanghai, China - ground zero of innovation in Industry 4.0. Already boasting an award-winning energy optimization and automation platform, ADEN continues to push forward with a vision of uniting the full spectrum of IFM solutions through our IoT platform.

ADEN operates in over 25 countries, with 80 cities in China alone. ADEN now has 26,000 employees around the world, ensuring that our partners receive comprehensive, top-level facility services at every level. We partner with clients in commercial, industrial and private sectors; among these, many companies listed on the Fortune 500 count on ADEN for strategic outsourcing.



Tel : +86 21 54657968
Email : corporate.communication@adenservices.com
Website : www.adenservices.com

GOLD SPONSOR**Dell EMC**

Dell Technologies is a unique family of businesses that provides the essential infrastructure for organizations to build their digital future, transform IT and protect their most important asset, information. The company services customers of all sizes across 180 countries – ranging from 98 percent of the Fortune 500 to individual consumers – with the industry's most comprehensive and innovative portfolio from the edge to the core to the cloud.



Tel : +65 6692 3437
Email : june.ho@dell.com
Website : www.dell EMC.com

GOLD SPONSOR**EM Services Pte Ltd**

EM Services is one of Singapore's largest estate and property management company with a suite of services across residential, commercial & industrial properties and also student accommodation. We believe that Estate Management is about creating real partnerships with the communities that we support. More than just maintenance and engineering, we believe in building a sense of belonging and co-ownership for our vibrant living spaces.



Tel : 6278 8282
Email : feedback@emservices.com.sg
Website : www.emservices.com.sg

SPONSOR & EXHIBITOR PROFILES

GOLD SPONSOR

JEC Singapore

JEC Singapore is established in Shanghai in 1923. Our headquarters is in Hong Kong and operates in Mainland China, Macau, Myanmar, The Philippines, Singapore and Thailand.

JEC offers a wide range of contracting and specialized services in the Building, Environmental Infrastructure and Transportation & Logistics Sector. JEC entered the Singapore market in 1998. We offer a wide range of Contracting and specialised Services in Air-conditioning and Mechanical Ventilation (ACMV) systems, M&E Facility Management, Specialty M&E solutions and Architectural Products & Fit out. We offer in-depth expertise of ACMV Contracting and Services through our wholly-owned subsidiary - Thermal Private Limited, a highly recognised specialist in the ACMV market.



Tel : +65 6362 0660
Email : inquiry@jec.com
Website : www.sg.jec.com

GOLD SPONSOR

Sensorla

Sensorla provides workforce task management system that is activated by sensors and wearables.

- Task Management
- Work Order Planner
- Fault Reporting/ Service Request
- Smart Toilet Sensors (i.e. People Counter and Ammonia Sensors)

In addition to giving the supervisor awareness of staff's location and heart rate, the Smartband allows the supervisor to send ad-hoc tasks to the staff. The key advantage of the Smartband over the phone app option is the hands-free benefit, so that staff are not required to retrieve their phones constantly to answer to notifications. The Smartband also complements other technologies such as Smart Toilets to facilitate on-demand cleaning.



Tel : +65 6909 6483
Email : sherlyn.tan@sensorla.co
Website : www.sensorla.co

GOLD SPONSOR

UEMS Solutions Pte Ltd

UEMS Solutions Pte Ltd is an Integrated Facilities Management (IFM) company in Singapore providing environmental services in healthcare and non-healthcare sectors as well as property and facilities management services to both private and public sectors.

The whole suite of services that we provide include housekeeping, disinfection, portering, linen and laundry, external facade management, facilities management, facilities engineering, project consultancy and project management, energy management as well as corporate real estate services across all sectors in Singapore.

The Company has an excellent and long-established track record of 30 years with a diverse clientele base comprising top-tier hospitals, Fortune 500 companies, blue-chip MNCs, as well as leading local enterprises.



Tel : +65 6818 3600
Email : sg.sales@uemsgroup.com
Website : www.uemsgroup.com

SILVER SPONSOR

Digital Lumens

As an OSRAM business, Digital Lumens is driving the industrial IoT (IIoT) revolution by providing superior software, smart sensors, and system integration. Its cloud-based intelligence platform, SiteWorx, brings the tangible benefits of the IIoT to manufacturing, logistics, and other industrial environments worldwide, and leverages the power of intelligent, connected lighting and wireless IoT sensors to deliver business intelligence from a unique vantage point — overhead.

Its IIoT solutions have been deployed across nearly 500 million square feet of space, and delivered proven results for real-world clients in 45 countries.



Tel : (617) 723 1200
Email : info@digitallumens.com
Website : www.digitallumens.com

SILVER SPONSOR**FSI**

Established in 1990, FSI is a global-leader in CAFM software, with offices in the UK, Australia, Dubai, Canada and Hong Kong, plus an international partner network. FSI has been a major influence on CAFM/IWMS technology for the built environment, delivering a truly versatile business tool.

FSI focuses on developing integrated workplace systems to enhance the client experience, and the Concept range helps to boost productivity, streamline business processes, support improved performance and increase profitability, in organisations of every type and size.



Tel : +44(0) 1708 251900
Email : enquiries@fsifm.com
Website : www.fsifm.com

SILVER SPONSOR**Planon Asia Pte Ltd**

With over 35 years of facilities management experience, Planon is the leading global provider of software that supports organisations who aim to optimise workplaces, services and assets. Planon delivers innovative software, proven best practices and professional services that increase workplace productivity and cost efficiency. Planon's software is developed in-house and all components are fully integrated to deliver reliable management information.

Gartner – the leading independent technology research organisation – has consistently rated Planon as a global leader in their Magic Quadrant for Integrated Workplace Management Systems (IWMS). Planon has implemented its comprehensive solutions for over 2,500 clients, supported by offices around the world.



Tel : +65 6488 2133
Email : info-SG@planonsoftware.com
Website : www.planonsoftware.com

SILVER SPONSOR**Serraview**

Serraview is a global provider of SaaS-based workplace optimization and workforce enablement solutions, enabling CRE professionals to manage and deliver today's modern workplace. Our solutions are designed to increase real estate portfolio utilization, streamline operations, and enable smarter, more productive work environments. No matter if your workplace is traditional, agile or a combination, our workforce management solutions provide real time insights about your portfolio — insights that can be leveraged to boost productivity and enhance collaboration. Our solutions also have the flexibility to integrate with an existing IWMS system or it can be installed as a singular platform in as little as eight weeks.



Tel : +1 (800) 903 3716
Email : info@serraview.com
Website : www.serraview.com

ECOBAG SPONSOR**Conference & Exhibition Management Services Pte Ltd**

Established in 1980, CEMS is a regional organizer with a global perspective. A key player in the Meeting, Incentive, Convention and Exhibition (MICE) industry in Singapore, CEMS has vast knowledge and experience in organizing and managing exhibitions, conferences and other special events for government agencies, associations and private enterprises, with business activities spanning across many countries in ASEAN including Singapore, Thailand, Malaysia, Myanmar and the Philippines, China in North Asia, and India, Sri Lanka, Bangladesh and Pakistan in the South Asia. In October 1997, CEMS achieved the distinction of being the first professional conference and exhibition organiser in Singapore to obtain the ISO 9002 certification. For the past decade, CEMS has formed strategic partnerships with both local and international players to achieve mutually desirable goals in the MICE industry.



Tel : +65 6278 8666
Email : info@cems.com.sg
Website : www.cems.com.sg

SPONSOR & EXHIBITOR PROFILES

LANYARD SPONSOR

C&W Services Pte Ltd

C&W Services Singapore is in the business of preparing the world of FM for what's NEXT.

C&W Services is the facilities and engineering arm of Cushman & Wakefield in Singapore. We have over three decades of experience delivering professional, world-class end-to-end facilities management services and solutions to our clients, offering strategic and customised solutions to help clients meet their workplace goals. We are flexible in the types commercial models applied to achieve the highest cost savings, transparency and value-creation to our clients, whilst leveraging on smart technology solutions and innovation to maximise the quality, speed and cost of operations. We aim is to provide innovative self-performed services to a diverse portfolio of clients and market segments. We continually invest in our workforce of over 1,800 people and value high performance and extraordinary client service as a way to achieve our strategic vision.



Tel : +65 6876 0088
Email : Mohdtaha.a@cwservices.com
Website : www.cwservices.sg

STUDENT AWARD CATEGORY SPONSOR

Surbana Jurong Pte Limited

Surbana Jurong is one of the largest Asia-based urban and infrastructure consulting firms. Headquartered in Singapore, the Surbana Jurong Group has a global workforce of over 14,000 employees in more than 120 offices across over 40 countries in Asia, Australia, UK, the Middle East, Africa and the Americas, and an annual turnover of around S\$1.5 billion.

Surbana Jurong has a track record of close to 70 years, and has built more than a million homes in Singapore, crafted master plans for more than 30 countries and developed over 100 industrial parks globally. In facilities management, it has over twenty years' experience managing every aspect of the built environment.



Tel : +65 6248 1288
Email : BD@surbanajurong.com
Website : www.surbanajurong.com

EXHIBITOR

Delta Energy Ent Pte Ltd

Delta Energy Ent Pte Ltd is the local distributor of Globatech Australia.

H2oBioSonic, by Globatech Australia, is an Electronic Bio-Fouling Growth Prevention system. There is great room for improvement in the HVAC sector by providing our advanced ultrasonic technology to controlling algae, bacteria, scale and legionella in Cooling Towers and the Water column as an environmentally friendly and effective alternative to chemical dosing. Ultra-sonication is a proven sterilization technique & H2oBioSonic has had well over 10 years' experience perfecting our technology, algorithms & electronics maximising the effects.

Globatech Australia has dominated the Ultrasonic MGPS (Marine Growth Prevention System) market for over 8 years, in operation all around the world for the control of algae and barnacles in all areas of marine from structures & rigs to pleasure craft & pipework's.



Tel : +61 416 754 030
Email : michael@deltaenergysingapore.com
Website : www.Globatch.com.sg

EXHIBITOR

FaMe

FaMe is a worldwide leading software developer for Facility Management and Smart Buildings Solutions. Over 23 Modules cover all aspects of Building Operation. Space Management, Workplace Management, Maintenance or Energy Management are only some modules of the comprehensive solution. All modules are seamless integrated. The latest developments include also a state of the art Workplace Management. The FaMe Workplace Management concept supports classic booking functions as well as new Hot Desk or Homebase concepts with on-demand booking via web, smartphone, door plate or kiosk system. The online integration with Sensors and Aktors increase the comfort and minimize the costs.



Tel : (+49) 0 42 07/91 100
Email : contact@fame-online.de
Website : www.fame-online.com



ABOUT SINGAPORE

Where **passion and possibilities** meet

Singapore is much more than the sum of its numerous attractions. It's constantly evolving, reinventing, and reimagining itself, with people who are passionate about creating new possibilities.

It's where foodies, explorers, collectors, action seekers, culture shapers, and socialisers meet and new experiences are created every day.

Don't stop at finding out what you can do when you visit. Let our Passion Ambassadors show you what you can be when you're here. Because we're more than just a destination. We're where passion is made possible.

Source: Singapore Tourism Board



THANK YOU FOR BEING A PART OF



WORLD WORKPLACE ASIA 2019